

INDUSTRIAL DIESEL ENGINE

**KUBOTA 03-M SERIES (4-cylinder)**

# V2203-M-E3B



## RATED POWER

**35.9kW@2800rpm**



Photograph may show non-standard equipment.

## PERFORMANCE CURVE

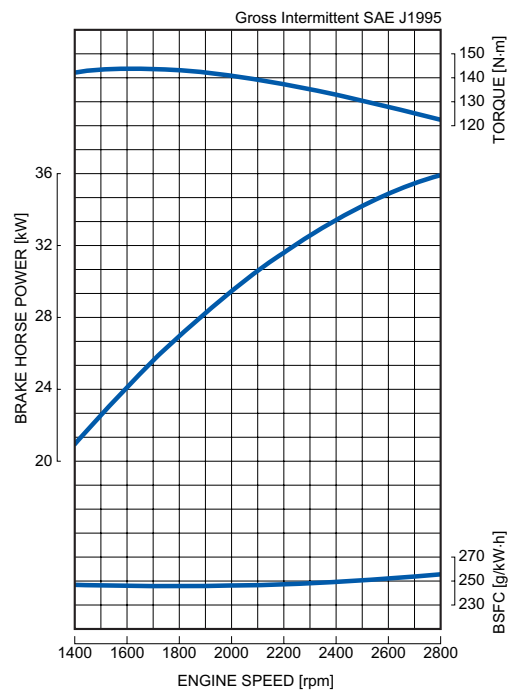

## FEATURES and BENEFITS

### Emissions

- The V2203-M engine complies with EPA Interim Tier 4 emissions regulations that are effective through the end of 2012. This engine also complies with EU Stage IIIA requirements that are effective through 2012 and beyond in the European market.

### Durable Power

- The Kubota 03-M Series is well recognized for industrial applications. With numerous features such as a built-in solenoid, low fan position, and single side serviceability, this engine offers excellent performance characteristics and application flexibility.
- The cooling water passages between the cylinder bores, using Kubota's original casting technology as a countermeasure against heat load of high power density, provides both superior endurance and reliable engine characteristics.
- The V2203-M engine offers a seamless transition from Tier 2 to Interim Tier 4 by maintaining the same footprint and hard mounting points with only slight performance changes from the Tier 2 engine.

### Clean and Quiet Power

- Kubota's original E-TVCS (Three Vortex Combustion System) has been improved. The airflow, combustion chamber and piston recess were optimized to provide a 50% lower particulate matter (PM) level, the same stringent level as above the 37kW class (EPA Interim Tier 4 Option 1).
- The half-float valve cover and MoS<sub>2</sub> coated pistons lower noise levels by 1.0-2.0 dBA over conventional diesel engines and provide reduced transmitted vibration from the valve area for better noise characteristics.

### Option

- The Kubota 03-M Series engines offer side power take-off(PTO), in response to the trend of increasing hydraulic control devices in industrial machines. It is possible to install a hydraulic pump at two side PTO locations.

## GENERAL SPECIFICATION

Model		<b>V2203-M-E3B</b>
Emission Regulation		Interim Tier 4 / Stage III A
Type		Vertical 4-cycle Liquid Cooled Diesel
Number of Cylinders		4
Bore	mm (in)	87 (3.43)
Stroke	mm (in)	92.4 (3.64)
Displacement	L (cu.in)	2.197 (134.1)
Combustion System		IDI
Intake System		Naturally Aspirated
Maximum Speed	rpm	2800
Output: Gross Intermittent	kW	35.9
	hp	48.1
	ps	48.8
Direction of Rotation		Counterclockwise Viewed on Flywheel
Oil Pan Capacity	L (gal)	7.6 (2.01) [US] / 9.5 (2.51) [EU]
Starter Capacity	V-kW	12-1.4
Alternator Capacity	V-A	12-40
Length	mm (in)	667.1 (26.3)
Width	mm (in)	499.0 (19.6)
Height (1)	mm (in)	633.5 (24.9) [US] / 679.0 (26.7) [EU]
Height (2)	mm (in)	220.0 (8.7) [US] / 265.5 (10.5) [EU]
Dry Weight	kg (lb)	180.0 (396.9)

\*Specification is subject to change without notice.

\*Output: Gross Intermittent SAE J1995

\*Dry weight is according to Kubota's standard specification.

When specification varies, the weight will vary accordingly.

## DIMENSIONS

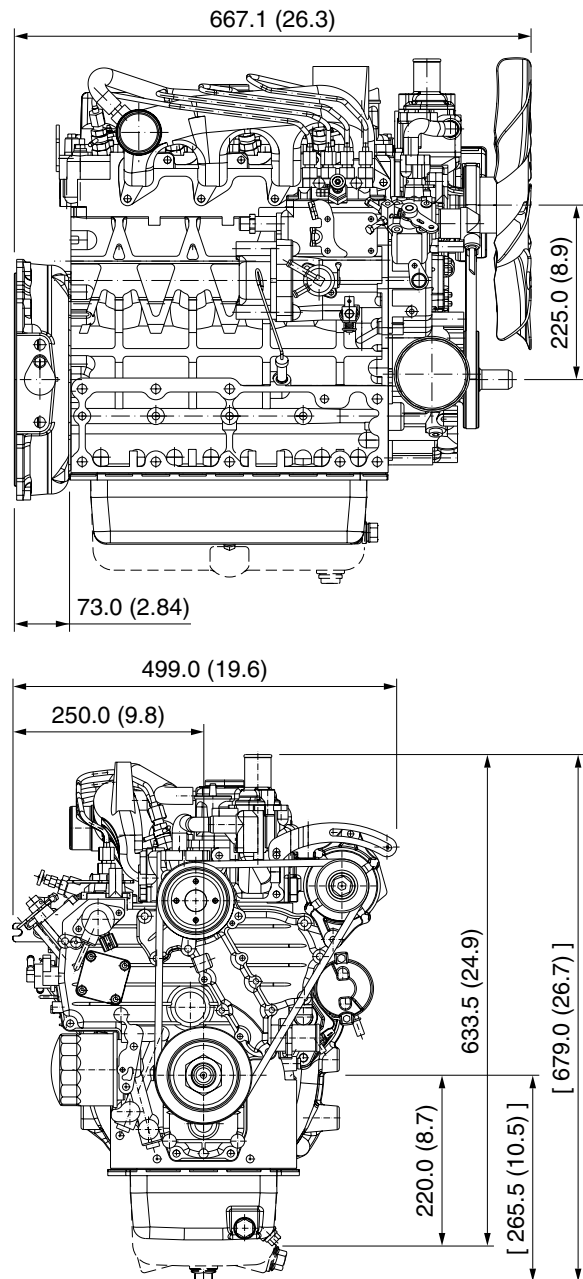

[ ] EU spec



## KUBOTA Corporation

2-47, Shikitsuhigashi 1-chome, Naniwa-ku, Osaka, 556-8601 Japan  
Fax: 06-6648-3521

<http://www.engine.kubota.ne.jp>

Your Driving Force  
KUBOTA ENGINE