

CANplus™ 750 Automatic Start/Stop Series

FOR ELECTRONICALLY GOVERNED AND MECHANICALLY GOVERNED ENGINES

DESCRIPTION

The LOFA CANplus™ 750 (CP750) Series is a universal platform to monitor, control and automatically start/stop both electronically and mechanically governed diesel engines. On electronically governed engines, the CANplus™ displays diagnostic messages from the engine ECU as well as two additional fault inputs. On mechanically governed engines, the CANplus™ also performs the ECU function by monitoring low oil pressure, high temperature and two additional engine faults. An analog fuel level input broadcasts the fuel level across the SAE J1939 CANbus to the display and other devices. The microprocessor-based solid-state design uses high power semiconductors instead of outdated electromechanical relays to ensure reliable high current switching.

A single momentary rocker switch adjusts the throttle using the CANbus for electronically governed engines. An optional panel mounted rotary digital throttle with push-to-set speed selector or a remote mounted vernier potentiometer are also available for throttle control. The integrated automatic start/stop functionality combined with the configurable throttle ramp time and engine speed limits makes the CANplus™ an ideal autostart control system. For automated pump applications, the panel can easily be configured in the field for wide variety of pumping applications utilizing float switches or transducers for level, pressure or flow.

The large LCD display (4.25" diagonal) shows virtually any SAE J1939 parameter reported by the ECU, including RPM, engine temperature, oil pressure and diagnostic codes. The display can be easily configured to customer preference concerning gauge type (analog or digital), gauge arrangements, gauge size, and language (8 languages supported). For automated pump applications, the display shows float states as well as transducer level. The LCD is clearly readable in both bright sunlight as well as total darkness and is housed in a rugged IP67 rated housing. The five integral push buttons allow configuration and operation of the display modes. Four bright LEDs below the display indicate Preheat, Autostart, Warning and Stop status.

The CP750 allows each system to be field configured to suit the customer's unique requirements. Most common operational parameters can be configured from the display. Less frequently used parameters are configured from virtually any computer using the easy to operate configuration program. Optional analog gauges can be installed for analog sensors or to display many ECU parameters with a simple add-on module.

Automatic Start/Stop Operation

The CP750 features advanced Automatic Start/Stop control to meet almost any requirement. The two switch inputs and a 4-20mA transducer input support a number of control scenarios. A 0-5 VDC transducer input is available as an option.

Single switch mode allows reliable operation with a single switch. Dual switch operation allows reliable operation with greater hysteresis.

The transducer supports simple start/stop and start/stop with level, flow or pressure maintenance modes.

- Configurable high and low set points control start/stop operation
- Maintenance mode monitors the operating set point and adjusts the engine speed to match the set point with configurable aggressiveness

The dual switch inputs can be combined with the transducer input for back-up safety control to protect against transducer clog or failure.



Pictured Above: CP750G2RD



Above: Rotary digital throttle with push-to-set speed selector allows for changes to Auto-start Operate RPM within pre-defined operational limits

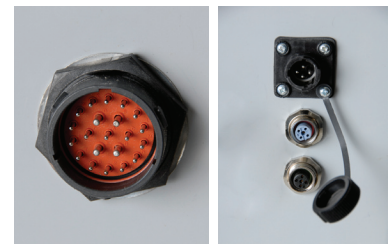

Above Left: Deutsch 21 pin engine harness connector
Above Right: CPC sealed dual float switch connector with cap
Middle: M12 sealed transducer connector (cap not shown)
Bottom: M12 sealed RS485 serial connector (cap not shown)



FEATURES AND BENEFITS

- Universal engine support for both electronically and mechanically governed engines
- Engine monitoring and diagnostics via First-Fault Diagnostics (FFD)
- Large backlit IP67 LCD displays parameters and diagnostics - clearly readable in both bright sunlight as well as total darkness
- Super-bright LEDs for Preheat, Autostart, Warning and Stop indication
- Integral throttle control via simple momentary rocker switch or optional rotary digital throttle with push-to-set speed selector for CANbus throttle
- Heavy-duty IP64 water-resistant key switch with booted key capable of up to 75A @ 12V (removable in autostart position)
- Heavy-duty polycarbonate NEMA 4X enclosure with lockable door and isolation mounting designed to withstand the most extreme industrial applications
- Alarm output to signal start warning or shutdown conditions
- Output for engine running, autostart armed or load switch
- Simple plug-and-play installation customized to the specific application allows rapid equipment completion
- Versatile design enables customization for customer's specific applications
- Optional powder-coated Aluflex™ aluminum enclosure with isolation mounting

Configurable Features

- J1939 Parameters
- Autostart Parameters
 - Operating Mode
 - Switch Polarity (NO/NC)
 - Transducer Parameters
 - Throttle Settings
- Analog Fuel Sender
- Mechanically Governed Engine

Parameters

- Over Speed RPM
- Preheat Control
- Shutdowns

The standard panel terminates to a sealed Deutsch weatherproof plug. This connector offers a robust connection that performs well in harsh environments and allows for simplified installation. The design allows installing custom plug-and-play engine wiring harnesses as well as standard harness extensions.

DIMENSIONS

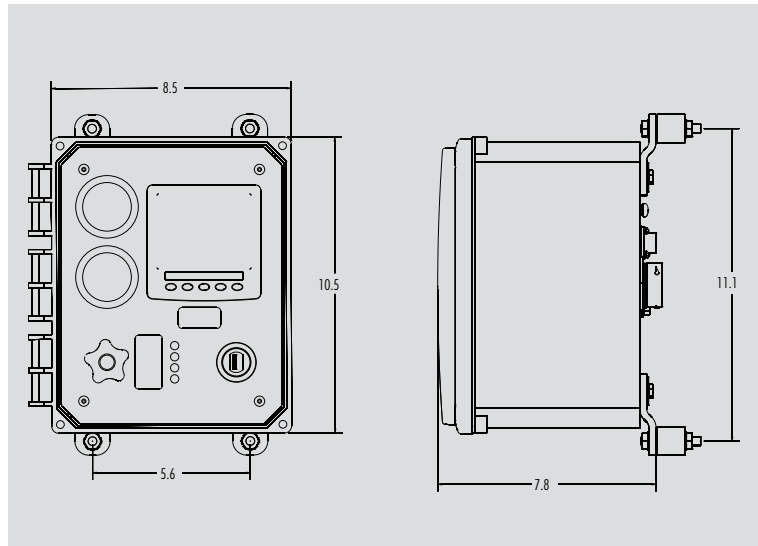

SPECIFICATIONS

- Standby current: 20 mA @ 12 VDC, 40 mA @ 24 VDC
- Operating temperature: -13° to 167° F (-25° to 75° C)
- Key Switch: 75 A for 1 second (5% duty cycle)/18 A continuous @ 12V; 25,000 mechanical cycles)
- Reverse polarity protection
- 2-year limited warranty

Solid State Inputs/Outputs

- SAE J1939 Bus (CANbus 2.0B)
- ECU/Solenoid Control Output (10 A continuous)
- Starter Solenoid Output (70A 1 second, 10 A continuous)
- Auxiliary Multipurpose Output (1 A continuous)
- Alarm Output (1 A continuous)
- 2 Autostart Switch Inputs
- Transducer Autostart Input (4-20 mA or optional 0-5 VDC)
- 2 Auxiliary Shutdown Switch Inputs
- Fuel Sender Analog Input
- RS485 Serial Interface for Auxiliary Equipment

Mechanical Engines Only

- Preheat Indication Input (ground or battery active)/Preheat Control Output (ground active)
- Tachometer Input
- Temperature Switch Input
- Oil PSI Switch Input
- Oil PSI Sender Analog Input
- Temperature Sender Analog Input