

VOLVO PENTA INDUSTRIAL DIESEL

TAD1650VE

397 kW (540 hp) crankshaft power acc. to ISO 3046

The TAD1650VE is a powerful, reliable and economical Versatile Diesel Engine built on the dependable Volvo in-line six concept.

Durability & low noise

Designed for easy, fast and economical installation. Field tested to ensure highest standard of durability and long life. Well-balanced to produce smooth and vibration-free operation with low noise level.

To maintain a controlled working temperature in cylinders and combustion chambers, the engine is equipped with piston cooling. The engine is also fitted with replaceable cylinder liners and valve seats/guides to ensure maximum durability and service life of the engine.

Operational economy and Low exhaust emission

The state of the art, high-tech injection and air charging system with low internal losses contributes to excellent combustion and low fuel consumption.

The TAD1650VE complies with EPA/CARB Tier 3 and EU stage III exhaust emission regulations. These regulations are met by using V-ACT™ (Volvo Advanced Combustion technology).

V-ACT includes a flexible high pressure fuel injection system, an air management system including an internal exhaust gas recirculation device and an enhanced electronic controller.

Easy service & maintenance

Easily accessible service and maintenance points contribute to the ease of service of the engine.

Technical description:

Engine and block

- Optimized cast iron cylinder block with optimum distribution of forces without the block being unnecessary heavy.
- Wet, replaceable cylinder liners
- Piston cooling for low thermal load on pistons and reduced ring temperature
- Tapered connecting rods to reduce risk of piston cracking
- Crankshaft induction hardened bearing surfaces and fillets with seven main bearings for moderate load on main and big-end bearings
- Nitrocarburized transmission gears for heavy duty operation
- Keystone top compression rings for long service life



Features

- High torque
- Air to air intercooler
- Fully electronic with Volvo Penta EMS 2
- High power density
- EPA / CARB Tier 3 / EU stage 3 emission compliant
- Low noise levels

- Viscous type crankshaft vibration damper
- Replaceable valve guides and valve seats
- Over head camshaft and four valves per cylinder equipped with camshaft damper to reduce noise and vibrations.

Lubrication system

- Full flow oil cooler
- Full flow disposable spin-on oil filters, for extra high filtration
- Gear type lubricating oil pump, gear driven by the transmission

Fuel system

- Self de-aerating system. When replacing filters all fuel stays in the engine.
- Non-return fuel valve
- Electronic Unit Injectors
- Fuel prefilter with water separator and water-in-fuel indicator / alarm
- Gear driven low-pressure fuel pump
- Fuel pressure switch

Turbo charger

- Efficient and reliable turbo charger
- Extra oil filter for the turbo charger

Cooling system

- Belt driven, maintenance-free coolant pump with high degree of efficiency
- Coolant filter as standard
- Efficient cooling with accurate coolant con-

trol through a water distribution duct in the cylinder block. Reliable sleeve thermostat with minimum pressure drop

Electrical system

- Engine Management System 2 (EMS 2), an electronically controlled processing system which optimizes engine performance. It also includes advanced facilities for diagnostics and fault tracing
- The instruments and controls connects to the engine via the CAN SAE J1939 interface, either through the Control Interface Unit (CIU) or the Digital Control Unit (DCU). The CIU converts the digital CAN bus signal to an analog signal, making it possible to connect a variety of instruments. The DCU is a control panel with display, engine control, monitoring, alarm, parameter setting and diagnostic functions. The DCU also presents error codes in clear text.
- Sensors for oil pressure, oil temp, boost pressure, boost temp, coolant temp, fuel temp, water in fuel, fuel pressure and two speed sensors. Crank case pressure, piston cooling pressure and oil level.

**VOLVO
PENTA**

TAD1650VE

Technical Data

General

Engine designation	TAD1650VE
No. of cylinders and configuration.....	in-line 6
Method of operation	4-stroke
Bore, mm (in.).....	144 (5.67)
Stroke, mm (in.).....	165 (6.50)
Displacement, l (in ³).....	16.12 (984)
Compression ratio.....	18.0:1
Dry weight, kg (lb).....	1425 (3142)

Performance

ICFN Power, without fan, at 1800 rpm, kW (hp).....	397 (540)
Torque at 1400 rpm, Nm (lbf ft)	2551 (1881)

Lubrication system

Oil system capacity incl filters, liter (US gal).....	53 (14)
---	---------

For details see Technical data

Standard Equipment

Engine

- Automatic belt tensioner
- Lift eyelet (front)
- Flywheel for Clark 8000/9000 series
- Flywheel housing with conn. acc. to SAE 1
- Flywheel for 14" flex. plate and flexible coupling
- Vibration dampers

Engine suspension

- Fixed front suspension

Lubrication system

- Oil dipstick
- Full-flow oil filter of spin-on type
- By-pass oil filter of spin-on type
- Oil cooler, side mounted
- Low noise oil sump

Fuel system

- Fuel filters of disposable type (required)
- Electronic unit injectors
- Pre-filter with water separator (required)

Intake and exhaust system

- Air cooled exhaust manifold
- Exhaust flange with v-clamp
- Turbo charger, low right side
- Crankcase ventilation

Cooling system

- Belt driven coolant pump

Control system

- Engine Management System 2 (EMS 2) with CAN-bus interface SAE J1939
- Digital Control Unit (DCU)

Alternator

- Alternator 110 / 24 V

Starting system

- Starter motor, 7.0kW, 24 V
- Connection facility for extra starter motor

Instruments and senders

- Temp.- and oil pressure for automatic stop/alarm

Engine Packing

- Plastic wrapping

- optional equipment or not applicable

• included in standard specification

Engine

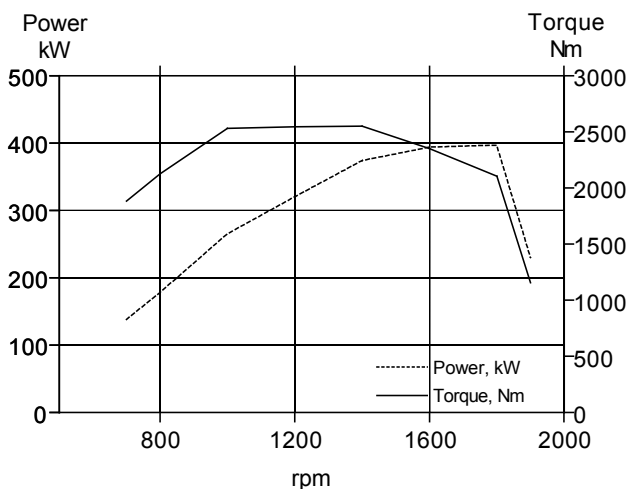

Dimensions TAD1650VE

Not for installation

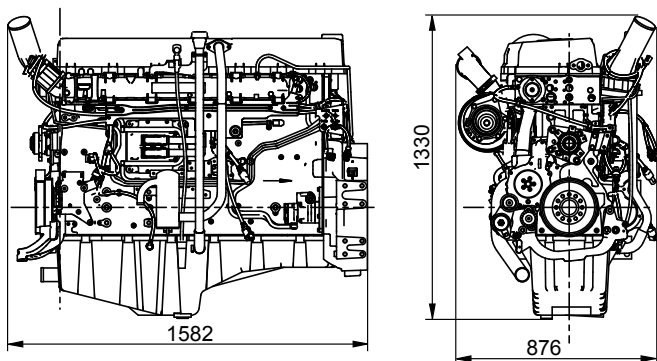

Note! Not all models, standard equipment and accessories are available in all countries. All specifications are subject to change without notice. The engine illustrated may not be entirely identical to production standard engines.

Power Standards

The engine performance corresponds to ISO 3046, BS 5514 and DIN 6271. The technical data applies to an engine without cooling fan and operating on a fuel with calorific value of 42.7 MJ/kg (18360 BTU/lb) and a density of 0.84 kg/litre (7.01 lb/US gal, 8.42 lb/Imp gal), also where this involves a deviation from the standards.

Rating Guideline

IFN Power rating corresponds to ISO Overload Power. It is intended for applications where intermittent power is

utilized less than 1 hour within any period of 12 hours of continuous operation. The average load factor must not exceed the continuous rating.

ICFN Power rating corresponds to ISO Standard Power for continuous operation. It is intended for constant load applications with uninterrupted service at full load for extended periods of time. The average load factor must not exceed 70% of the continuous rating, when operating at continuous speed and load.

VOLVO PENTA

AB Volvo Penta

SE-405 08 Göteborg, Sweden
www.volvopenta.com